

PRELIMINARY DATA SHEET

# SKY73013-306: Direct Quadrature Demodulator 4.9–5.925 GHz Featuring “No-Pull” LO Architecture

## Applications

- WiMAX, WLAN receivers
- UNII Band OFDM receivers
- RFID, DSRC applications
- Proprietary radio links

## Features

- RF is non-integer multiple of LO frequency
- Broadband RF: 4.9–5.925 GHz, LO: 3.268–3.952 GHz, IF: DC–100 MHz
- Single 3.3 V supply
- Very low LO drive level (-15 dBm)
- High dynamic range, low noise figure
- Excellent linearity and quadrature accuracy—suitable for 64-QAM OFDM
- Low current consumption
- Small 4 x 4 mm 16-lead QFN package
- Available lead (Pb)-free and RoHS-compliant

## Description

The Skyworks SKY73013-306 is an integrated receiver down-converter subsystem for the 4.9–5.925 GHz band. Its exceptional dynamic range and quadrature accuracy make this device an ideal solution for direct conversion and low-IF OFDM and single-carrier communications systems (including 64-QAM WiMax and WLAN).

The SKY73013-306 employs an innovative “no-pull” local oscillator (LO) architecture which offsets the required synthesizer frequency from that of the receiver center frequency by the non-integer factor of 3/2. This greatly improves the performance of direct conversion receiver architecture by eliminating dynamic DC offsets (caused by LO-RF leakage) and VCO pulling. This receiver frequency plan is compatible with the 3/2 “no-pull” modulator frequency plan.

## Functional Block Diagram

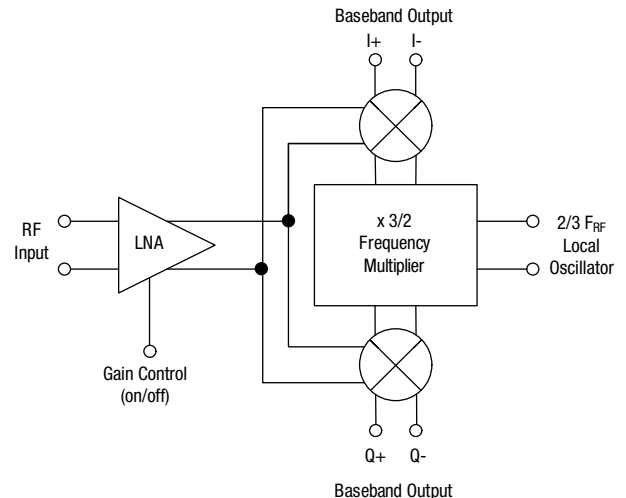

The SKY73013-306 contains a low noise amplifier at the RF input, the gain of which can be set to a high or low value via the gain control input. This LNA drives a highly linear quadrature mixer pair. The quadrature local oscillator signals to these mixer stages are provided by the 3/2 frequency conversion stage.

The nominal supply voltage for SKY73013-306 is 3.3 V. This part can operate over the temperature range of -40 °C to 85 °C.

An evaluation board is available upon request.

**NEW** Skyworks offers lead (Pb)-free, RoHS (Restriction of Hazardous Substances)-compliant packaging.



## Electrical Specifications

**V<sub>CC</sub> = 3.3 V, T = 25 °C, LO Input Power = -15 dBm, Z<sub>OUT</sub> = 1000 Ω Differential unless otherwise noted**

Parameter	Condition	Min.	Typ.	Max.	Unit
<b>DC Operating Conditions</b>					
Supply voltage		3	3.3	3.6	V
DC current			33		mA
<b>RF Performance</b>					
RF input frequency		4.9		5.925	GHz
LO input frequency		3.268		3.952	GHz
LO drive level		-20	-15	-10	dBm
RF input impedance	Differential		100		
LO input impedance	Differential		100		
IQ amplitude imbalance			0.15	0.25	dB
IQ phase error			2	3	Deg
Noise figure	Direct conversion measurement (no image), LNA Gain control voltage = V <sub>CC</sub> Direct conversion measurement (no image), LNA Gain control voltage = 0 V		6.0	8.5	dB
			26	27	dB
Voltage conversion gain <sup>(1)</sup>	LNA gain control voltage = V <sub>CC</sub> LNA gain control voltage = 0 V	22.5	24.5	26	dB
		0	2	4	dB
Input 1 dB compression point	LNA gain control voltage = V <sub>CC</sub> LNA gain control voltage = 0 V	-17	-15		dBm
		-16	-14		dBm
Input IP2	LNA gain control voltage = V <sub>CC</sub> LNA gain control voltage = 0 V		28		dBm
			32		dBm
Input IP3	LNA gain control voltage = V <sub>CC</sub> LNA gain control voltage = 0 V		0		dBm
			3		dBm
BB load impedance	Differential	500    15			Ω    pF
IF output common mode voltage		1.55	1.65	1.75	V
IF DC offset			10	20	mV
IF output linear signal swing	Differential			2	V <sub>pp</sub>
IF frequency range		DC		100	MHz
LO-to-RF isolation			61		dB

1. Voltage conversion gain = 20 log<sub>10</sub> (V<sub>OUT,rms</sub>/V<sub>IN,rms</sub>), independent of impedance.

### Typical Performance Data

$V_{CC} = 3.3\text{ V}$ ,  $T = 25\text{ }^\circ\text{C}$ , LO Input Power =  $-15\text{ dBm}$ ,  $Z_{OUT} = 1000\text{ }\Omega$  Differential unless otherwise noted

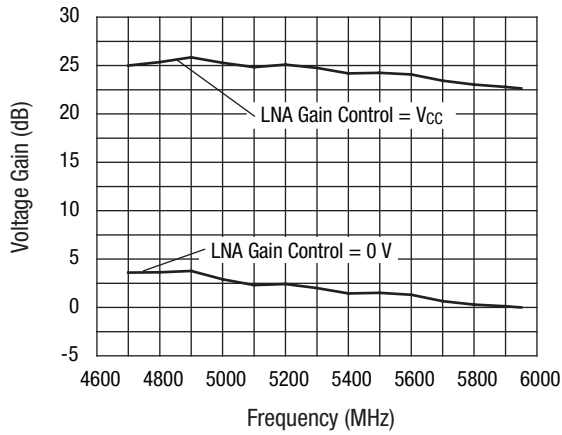

**Voltage Conversion Gain vs. Frequency**

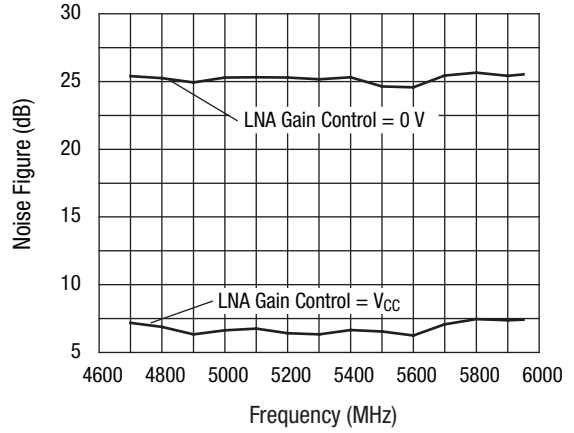

**Noise Figure vs. Frequency**

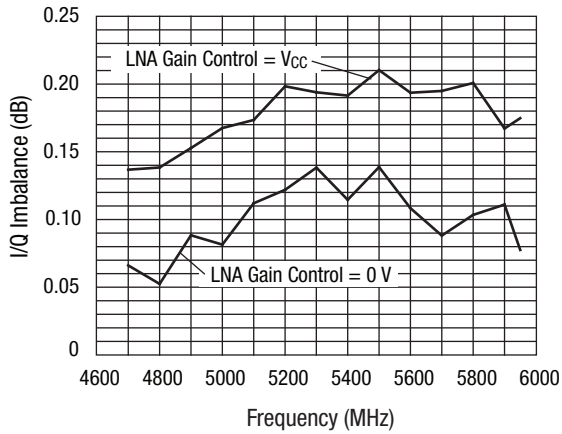

**I/Q Imbalance vs. Frequency**

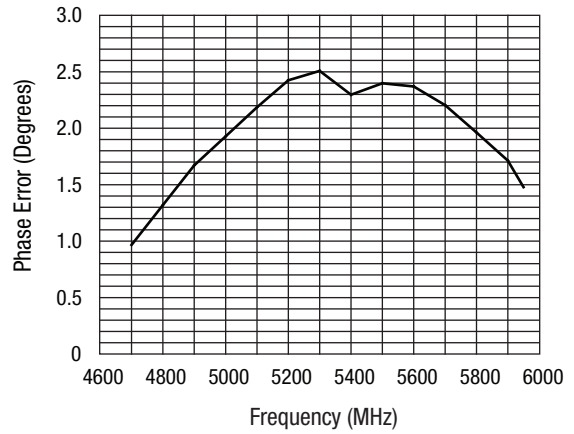

**Phase Error vs. Frequency**

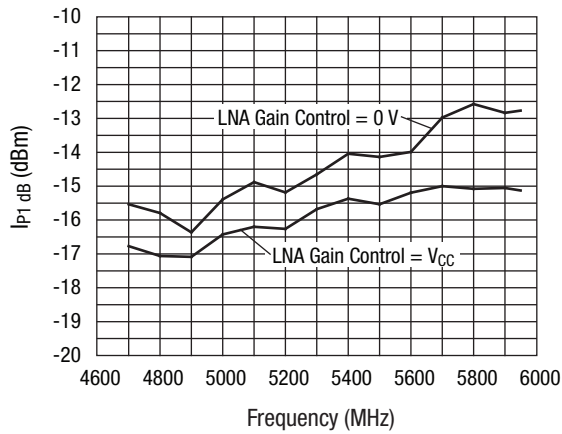

**Input 1 dB Compression Point vs. Frequency**

### Pin Out

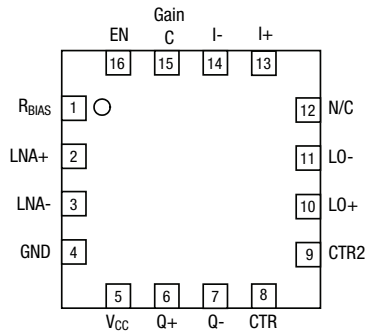

### Evaluation Board

The SKY73013 Evaluation Board is used to test the performance of the SKY73013 Direct Quadrature Demodulator. The evaluation board BOM is as shown in the table below.

The evaluation board for SKY73013 allows the part to be fully exercised. The board is populated with several components which are not required for normal operation but facilitate special testing of the SKY73013, such as two high gain, differential baseband amplifiers which are well-suited for differential-to-single-ended conversion, and are included for noise figure measurements.

The evaluation board requires a power supply voltage of 3.3 V nominal, that is capable of sourcing 50 mA.

### Evaluation Circuit PCB

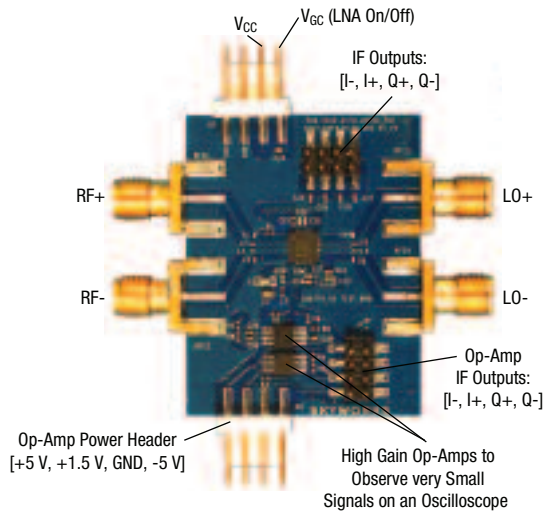

### Pin Descriptions

Pin #	Name	Description
1	R <sub>BIAS</sub>	Bias resistor. Nominal value = 1.2 k, 1%
2	LNA+	RF input +
3	LNA1	RF input -
4	GND	Ground
5	V <sub>CC</sub>	Supply voltage
6	Q+	BB/IF Q+ output
7	Q-	BB/IF Q- output
8	CTR1	Debug pin; connect to ground
9	CTR2	Debug pin; connect to ground
10	LO+	Local oscillator input +
11	LO-	Local oscillator input -
12	N/C	No connection
13	I+	BB/IF I+ output
14	I-	BB/IF I- output
15	GainC	Gain control; LNA is ON with V <sub>CC</sub> applied to this pin, off when grounded
16	EN	Chip enable; chip is enabled with V <sub>CC</sub> applied to this pin and disabled when this pin is grounded
Paddle		Must be connected via lowest possible impedance to ground for proper electrical and thermal performance

### Absolute Maximum Ratings

Characteristic	Value
RF Input Power	0 dBm
Supply voltage	4.5 V
Supply current	60 mA
LO input power	0 dBm
Operating temperature	-40 °C to +85 °C
Storage temperature	-65 °C to +85 °C

Performance is guaranteed only under the conditions listed in the specifications table and is not guaranteed under the full range(s) described by the Absolute Maximum specifications. Exceeding any of the absolute maximum/minimum specifications may result in permanent damage to the device and will void the warranty.

**CAUTION:** Although this device is designed to be as robust as possible, ESD (Electrostatic Discharge) can damage this device. This device must be protected at all times from ESD. Static charges may easily produce potentials of several kilovolts on the human body or equipment, which can discharge without detection. Industry-standard ESD precautions must be employed at all times.

## Evaluation Circuit Schematic

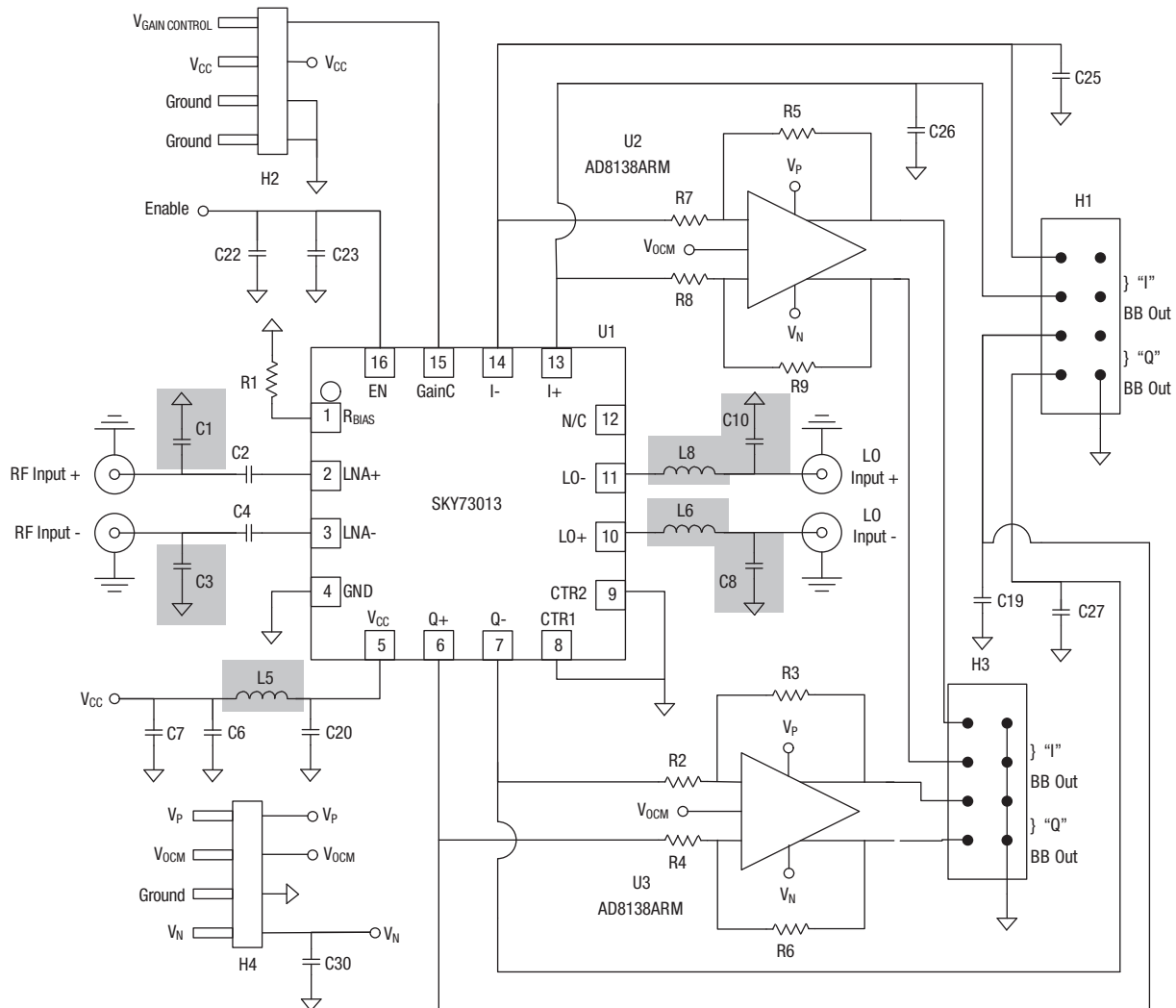

C1, C3, C8, C10 not installed. Zero  $\Omega$  resistors installed in positions L5, L6, and L8.  
U2, U3, and associated components are installed to facilitate noise figure measurements.

## Evaluation Board Test Procedure for Gain, Quadrature Accuracy, and Input Compression

Use the following testing procedure to set up the SKY73013 evaluation board for testing.

1. Connect a 3.3 V DC power supply to  $V_{CC}$  and either 3.3 V or 0 V to  $V_{GAIN CONTROL}$  (for high or low gain).
2. Connect a 100  $\Omega$  balun (recommended: Krytar 4020080 180° Hybrid, with the Summing port terminated with 50  $\Omega$ ) to the RF input input. Connect a vector signal generator to the input of the balun. Alternatively, at the expense of 3 dB signal loss, it is possible to drive the RF input single-ended with a 50  $\Omega$  source, as long as the opposite input is terminated with 50  $\Omega$ . Set this source to -20 dBm.
3. Connect a CW sine wave source, at 2/3 the RF frequency, to the LO. It is less critical to use a balun on this port, although it is still recommended. Set this source to -15 dBm .
4. Connect oscilloscope probes on the I+, I-, Q+ and Q- pins of header 1
5. Enable power supply.
6. Enable RF (set to CW) and LO power sources.
7. Observe quadrature amplitude balance and phase accuracy.
8. Adjust RF drive level to observe signal compression.

### Evaluation Board Test Procedure for Evaluating Noise Floor

This is procedure assumes that circuit is set up according to the procedure described above.

1. Reduce the input RF level to -60 dBm
2. Connect 5 V to the 5 V pin on header 4 to power the differential amplifiers U2 and U3.
3. Move the Oscilloscope probes to the I+, I-, Q+ and Q- pins of header 3. The differential amplifiers are included in the signal path because the IF output signals directly from the I and Q baseband outputs of the SKY73013 are smaller than the minimum required by most oscilloscopes to make a reasonable measurement, although these signal levels are well within the dynamic range of almost any op amp or variable gain amplifier.
4. Adjust RF signal generator level until demodulated noise is approximately equal to that of the downconverted sinusoid output level. This input signal level corresponds to the input-referred noise floor, the input level at which the output SNR is 0 dB.

### Circuit Design Considerations

The following design considerations are general in nature and must be followed regardless of final use or configuration.

1. Paths to ground should be made as short as possible, with lowest possible impedance.
2. The ground pad of the SKY73013 direct quadrature demodulator has special electrical and thermal grounding requirements. This pad is the main thermal conduit for heat flow from the die to the circuit board. As such, design the printed circuit board ground pad to dissipate the maximum heat produced by the SKY73013 and ensure that the method used to electrically and mechanically connect the SKY73010 package to this ground pad is adequate to allow for this heat flow.
3. Two external bypass capacitors on the Vcc pin are recommended. One larger-value capacitor should be used for low frequency bypassing and the other, smaller value capacitor for high frequency bypassing. The smaller capacitor should be physically located as near as possible to the SKY73013 V<sub>CC</sub> pin. Special attention should be given to ensure that the selected smaller capacitor does not go into parallel self resonance at the RF frequency.
4. The RF and LO inputs must be driven differentially for optimal performance. A 1:1 impedance balun is recommended for each with a center tap on the secondary side that is DC grounded. Special attention should be paid to ensure that the center tap has access to as “clean” a ground as possible.

### Evaluation Board Components

Component	Description	Default
C1, C3, C8, C10, C12, C17	Do not place	
C2, C4	0.5 pF	0201
C6	10 pF	0805
C7	100 pF	0603
C13, C14	2.7 pF	0402
C15, C18, C22, C24	1000 pF	0402
C19	5.1 pF	0402
C20	1 pF	0402
C21	0 Ω	0402
C23	100 pF	0402
C25, C26, C27	5.1 pF	0201
C28, C29, C30	0.1 μF	0402
H1, H3	8-pin SMT header	
H2, H4	4-pin header	
L5, L6, L8	0 Ω	0402
R1	1.2 k Ω 1%	0402
R2	510 Ω	0402
R3, R5, R6, R9	39k Ω	0402
R4, R7, R8	510 Ω	0402
RFC1, RFC2, RFC3, RFC4	SMA connector	
U1	SKY73013	
U2, U3	AD83138ARM	

### QFN-16 (4 X 4mm)

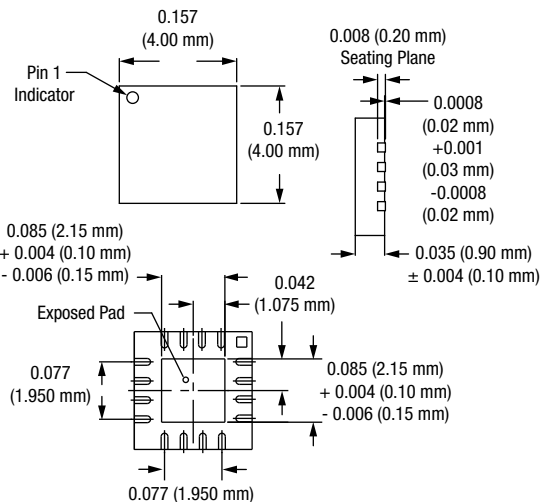

Copyright © 2002, 2003, 2004, 2005, 2006, 2007, 2008, Skyworks Solutions, Inc. All Rights Reserved.

Information in this document is provided in connection with Skyworks Solutions, Inc. ("Skyworks") products or services. These materials, including the information contained herein, are provided by Skyworks as a service to its customers and may be used for informational purposes only by the customer. Skyworks assumes no responsibility for errors or omissions in these materials or the information contained herein. Skyworks may change its documentation, products, services, specifications or product descriptions at any time, without notice. Skyworks makes no commitment to update the materials or information and shall have no responsibility whatsoever for conflicts, incompatibilities, or other difficulties arising from any future changes.

No license, whether express, implied, by estoppel or otherwise, is granted to any intellectual property rights by this document. Skyworks assumes no liability for any materials, products or information provided hereunder, including the sale, distribution, reproduction or use of Skyworks products, information or materials, except as may be provided in Skyworks Terms and Conditions of Sale.

THE MATERIALS, PRODUCTS AND INFORMATION ARE PROVIDED "AS IS" WITHOUT WARRANTY OF ANY KIND, WHETHER EXPRESS, IMPLIED, STATUTORY, OR OTHERWISE, INCLUDING FITNESS FOR A PARTICULAR PURPOSE OR USE, MERCHANTABILITY, PERFORMANCE, QUALITY OR NON-INFRINGEMENT OF ANY INTELLECTUAL PROPERTY RIGHT; ALL SUCH WARRANTIES ARE HEREBY EXPRESSLY DISCLAIMED. SKYWORKS DOES NOT WARRANT THE ACCURACY OR COMPLETENESS OF THE INFORMATION, TEXT, GRAPHICS OR OTHER ITEMS CONTAINED WITHIN THESE MATERIALS. SKYWORKS SHALL NOT BE LIABLE FOR ANY DAMAGES, INCLUDING BUT NOT LIMITED TO ANY SPECIAL, INDIRECT, INCIDENTAL, STATUTORY, OR CONSEQUENTIAL DAMAGES, INCLUDING WITHOUT LIMITATION, LOST REVENUES OR LOST PROFITS THAT MAY RESULT FROM THE USE OF THE MATERIALS OR INFORMATION, WHETHER OR NOT THE RECIPIENT OF MATERIALS HAS BEEN ADVISED OF THE POSSIBILITY OF SUCH DAMAGE.

Skyworks products are not intended for use in medical, lifesaving or life-sustaining applications, or other equipment in which the failure of the Skyworks products could lead to personal injury, death, physical or environmental damage. Skyworks customers using or selling Skyworks products for use in such applications do so at their own risk and agree to fully indemnify Skyworks for any damages resulting from such improper use or sale.

Customers are responsible for their products and applications using Skyworks products, which may deviate from published specifications as a result of design defects, errors, or operation of products outside of published parameters or design specifications. Customers should include design and operating safeguards to minimize these and other risks. Skyworks assumes no liability for applications assistance, customer product design, or damage to any equipment resulting from the use of Skyworks products outside of stated published specifications or parameters.

Skyworks, the Skyworks symbol, and "Breakthrough Simplicity" are trademarks or registered trademarks of Skyworks Solutions, Inc., in the United States and other countries. Third-party brands and names are for identification purposes only, and are the property of their respective owners. Additional information, including relevant terms and conditions, posted at [www.skyworksinc.com](http://www.skyworksinc.com), are incorporated by reference.